

Quick Installation Guide

SINGLE MPPT

① Overview

1.1 Packing List

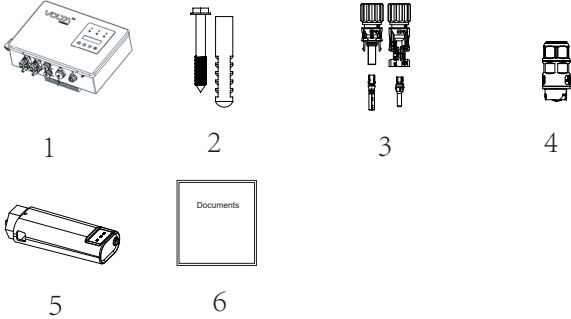

No.	Description	Quantity
1	Inverter	1
2	Expansion Screws	2
3	DC Connectors	2 Pairs
4	AC Connector	1
5	WiFi/GPRS Stick	1
6	Documents	1

1.2 Port Description

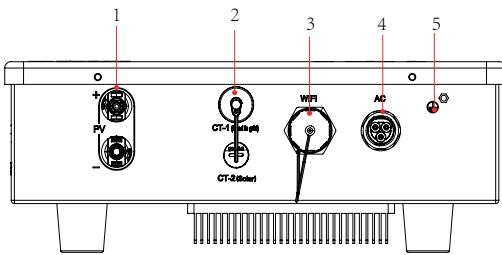

No.	1	2	3	4	5
Name	PV Ports	CT Port	Wifi/GPRS	AC Port	Grounding Port

② Mechanical Installation

2.1 Installation Requirement

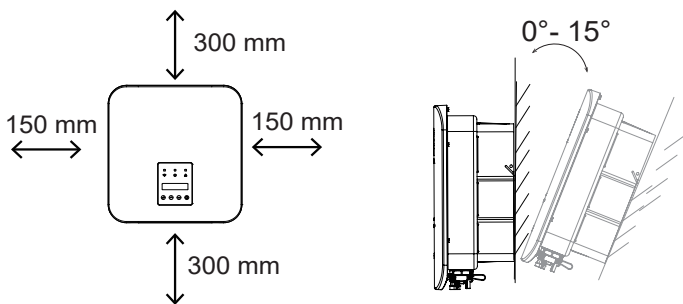

- 1) A minimum 150 mm clearance should be kept between two inverters and a minimum 300 mm clearance between inverters and the ground.
- 2) Install inverter vertically or with a backward tilt within 15°.

Warning
Do not select locations storing flammable material, which may cause fire or explosion!

2.2 Mounting

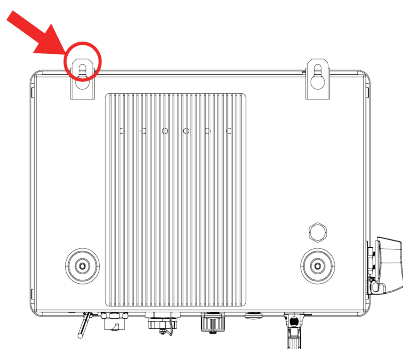

- 1) Drill 3 mounting holes of about 4 cm deep with a 10 mm drill bit
- 2) Insert expansion tubes into holes
- 3) Lock the inverter with screws.

2.3 Wifi/GPRS Stick Logger Installation

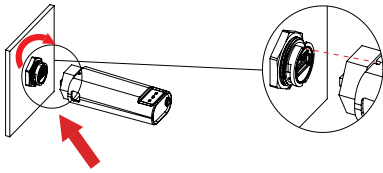

- 1) Plug the stick to the Wifi port on the inverter
- 2) Rotate the front operative part of the stick clockwise till the secure connection of the stick.

2.4 External Grounding Connection

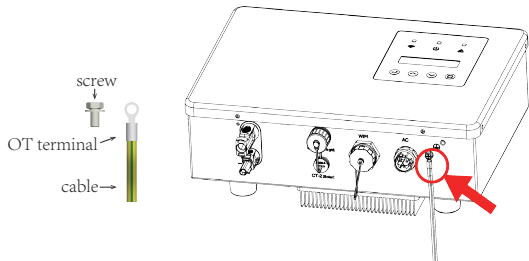

- 1) Crimp a grounding cable to the OT terminal
- 2) Insert a fastening screw into the OT terminal
- 3) Insert them to the grounding port of the inverter
- 4) Screw them together (the torque is 2 N.m.).

③ Electrical Connection

3.1 Assemble DC connectors

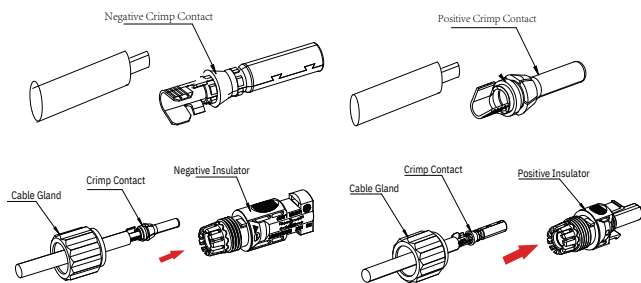

- 1) Strip off the DC Cable for a little length.
- 2) Insert the wire into the Crimp Contact and crimp them with an electrical crimp-er.
- 3) Thread the cable through the Cable Gland, insert it into the insulator, and gently pull back the cable to ensure firm connection.
- 4) Then screw up the Cable Gland to the Insulator.

3.2 Install DC connectors to Inverters

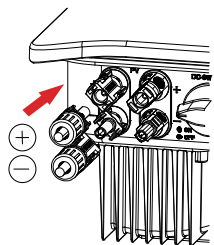

- 1) Turn the Grid Supply Main Switch OFF.
- 2) Turn the DC switch OFF.
- 3) Connect the DC connectors to the Inverter, small click confirms connection.

3.3 AC Side Connection of Inverters

- 1) Strip off the insulation of AC cable about 8 to 15 mm.
- 2) Thread the AC cable through the Cable Gland, Seal Ring and the Housing.

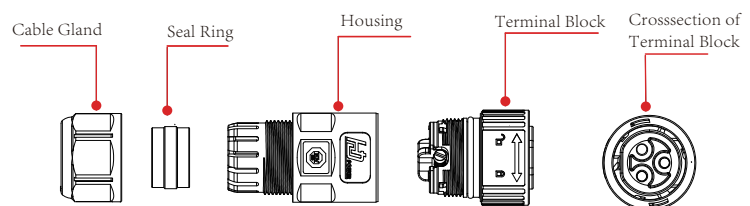

- 3) Connect wires to the Terminal Block: insert yellow green wire to the grounding (PE) terminal, red or brown to live line (L) terminal and blue or black to zero line (N) terminal; screw up screws on the Terminal Blocks with socket head wrench and pull back the wires to ensure firm connection.
- 4) Connect the Cable Gland, Seal Ring, Housing and Terminal Block together, a small click confirms secure connection.
- 5) Connect the AC connector to the inverter, a small click confirms connection.

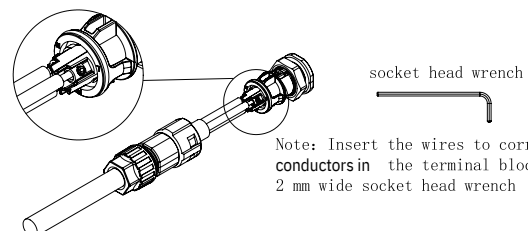

Note: Insert the wires to corresponding conductors in the terminal block with a 2 mm wide socket head wrench

3.4 Cable Selection

Cable Selection		Cable Size (in SQ. MM)			
Phase	Capacity (kW)	PVC Insulation		XLPE Insulation	
		Copper	Aluminium	Copper	Aluminium
Single	2 to 4.2	2.5	4	4	4
	5 to 6	4	6	4	4

3.4 User Manual



For Detailed Information Of Installation Procedure And Technical Information Please Download Our User Manual From The QR Code

Quick Installation Guide

DUAL MPPT

① Overview

1.1 Packing List

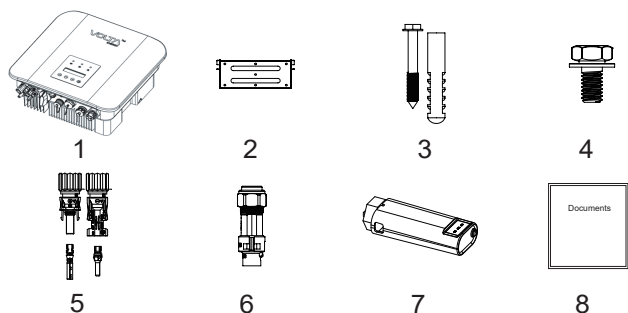

No.	Description	Quantity
1	Inverter	1
2	Wall Bracket	1
3	Expansion Screws	3
4	Fastening Screws	3
5	DC Connectors	2 Pairs
6	AC Connector	1
7	WiFi/GPRS Stick	1
8	Documents	1

1.2 Port Description

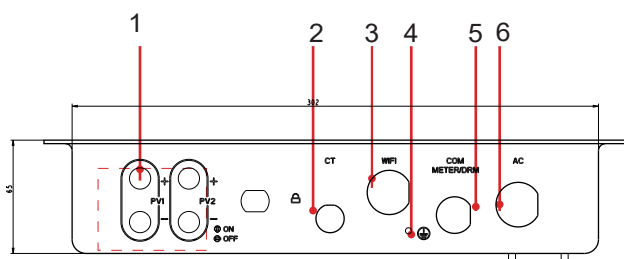

No.	1	2	3	4	5	6
Name	PV Ports	CT Port	Wifi/ GPRS	Grounding Port	COM/ Meter /DRM	AC Port

② Mechanical Installation

2.1 Installation Requirement

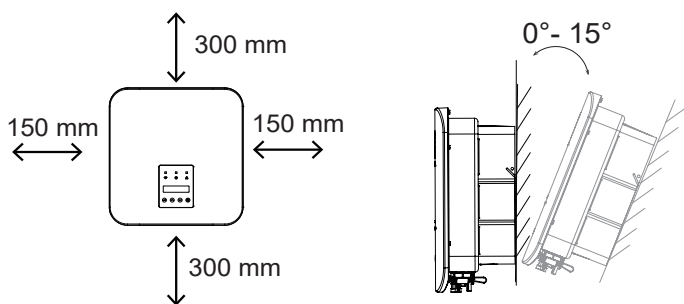

- 1) A minimum 150 mm clearance should be kept between two inverters and a minimum 300 mm clearance between inverters and the ground.
- 2) Install inverter vertically or with a backward tilt within 15°.

Warning Do not select locations storing flammable material, which may cause fire or explosion!

2.2 Mounting

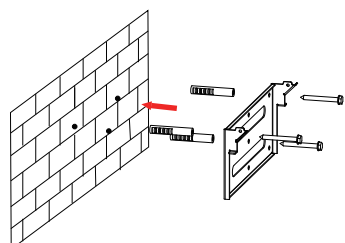

- 1) Drill 3 mounting holes of about 4 cm deep with a 10 mm drill bit
- 2) Insert expansion tubes into holes
- 3) Fix the bracket on the wall with screws

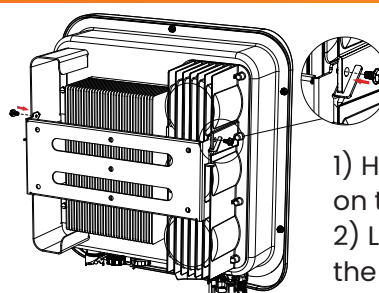

- 1) Hang the inverter on the bracket
- 2) Lock the inverter to the bracket with screws

2.3 Wifi/GPRS Stick Logger Installation

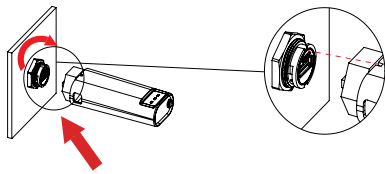

- 1) Plug the stick to the Wifi port on the inverter
- 2) Rotate the front operative part of the stick clockwise till the secure connection of the stick.

2.4 External Grounding Connection

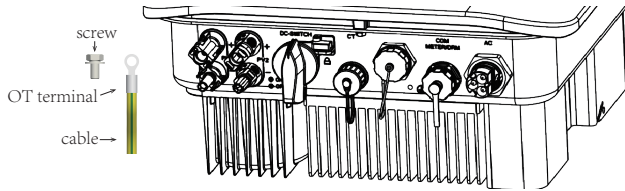

- 1) Crimp a grounding cable to the OT terminal
- 2) Insert a fastening screw into the OT terminal
- 3) Insert them to the grounding port of the inverter
- 4) Screw them together (the torque is 2 N.m.).

③ Electrical Connection

3.1 Assemble DC connectors

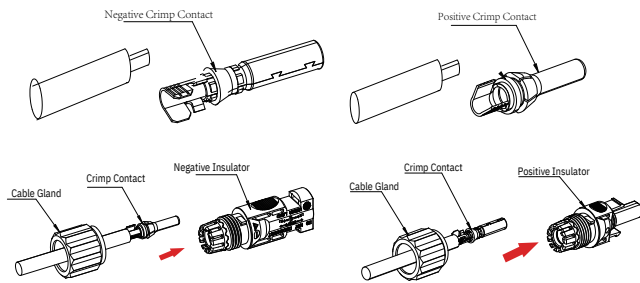

- 1) Strip off the DC Cable for a little length.
- 2) Insert the wire into the Crimp Contact and crimp them with an electrical crimp-er.
- 3) Thread the cable through the Cable Gland, insert it into the insulator, and gently pull back the cable to ensure firm connection.
- 4) Then screw up the Cable Gland to the Insulator.

3.2 Install DC connectors to Inverters

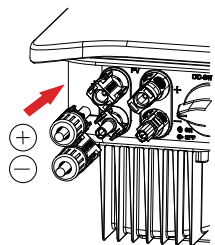

- 1) Turn the Grid Supply Main Switch OFF.
- 2) Turn the DC switch OFF.
- 3) Connect the DC connectors to the Inverter, small click confirms connection.

3.3 AC Side Connection of Inverters

- 1) Strip off the insulation of AC cable about 8 to 15 mm.
- 2) Thread the AC cable through the Cable Gland, Seal Ring and the Housing.

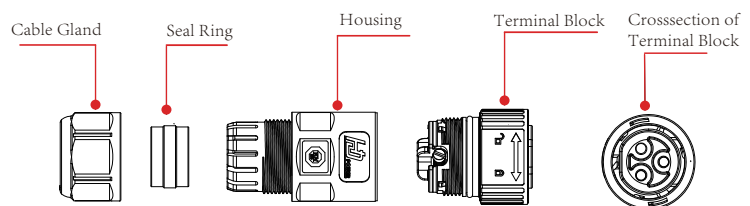

- 3) Connect wires to the Terminal Block: insert yellow green wire to the grounding (PE) terminal, red or brown to live line (L) terminal and blue or black to zero line (N) terminal; screw up screws on the Terminal Blocks with socket head wrench and pull back the wires to ensure firm connection.
- 4) Connect the Cable Gland, Seal Ring, Housing and Terminal Block together, a small click confirms secure connection.
- 5) Connect the AC connector to the inverter, a small click confirms connection.

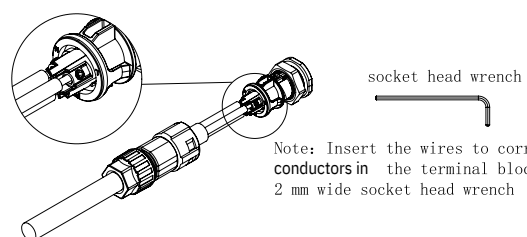

Note: Insert the wires to corresponding conductors in the terminal block with a 2 mm wide socket head wrench

3.4 Cable Selection

Cable Selection		Cable Size (in SQ. MM)			
Phase	Capacity (kW)	PVC Insulation		XLPE Insulation	
		Copper	Aluminium	Copper	Aluminium
Single	2 to 4.2	2.5	4	4	4
	5 to 6	4	6	4	4

3.5 User Manual



For Detailed Information Of Installation Procedure And Technical Information Please Download Our User Manual From The QR Code